

# Clausing Radial Drills

## Models CL1100 CL1230H



### Features and Standard Equipment:

- High-quality cast-iron arm with heat-treated and ground slides for smooth and accurate head positioning.
- The bearing bracket of gear-box is fitted with standard bearings to fit arm slide for smooth gear-box operation.
- High speed gears are made of Nickel-Chrome Steel and are heat-treated and ground for durability.
- Powerful 3 Hp, 2-speed, heavy-duty spindle drive motor.
- Overload protection device
- The main spindle is balanced by a specially shaped spring on model CL1100 and by an adjustable block on model CL1230H.
- Coolant System
- Low volt and overload protection
- Model CL1230H is equipped with hydraulic clamping. With a push of a button you can have arm unclamped then move vertically, or stop then clamp automatically.
- Tool kit and manuals

### Specifications:

Model	CL1100	CL1230H
<b>Working Area</b>		
Column Sleeve Dia (E)	10-1/4"	11-3/16"
Column Face to Spindle Center		
Maximum (D+C)	43-5/16"	48-7/16"
Minimum (D)	9-5/8"	13-3/8"
Spindle Head Travel (C)	33-5/8"	35"
Arm Vertical Travel (A-B)	24"	34-5/8"
Arm Rotation (Right & Left)	180°	180°
Base Surface to Spindle End		
Maximum (A)	50-3/8"	54"
Minimum (B)	17"	19-3/8"
Baseplate Working Surface	48" x 28-1/8"	48" x 28-1/8"
Box Table Area		
Top (L x K)	25" x 20-1/2"	25" x 20-1/2"
Side (H x L)	25" x 16-5/16"	25" x 16-3/8"
Base Dimensions		
Floor Area (R x S)	67-7/8" x 28-1/8"	67-11/16" x 27-15/16"
Height (Q)	7-1/16"	6-1/2"
<b>Drilling Head</b>		
Spindle Taper	MT#4	MT#4
Spindle Stroke	9"	9-7/8"
Quill Diameter	3.15"	3.15"
Spindle Speeds (rpm)	44-1500	44-1500
Number of Spindle Speeds	12	12
Spindle Feed Rate (in/rev.)	0.002", 0.004" & 0.006"	0.002", 0.004" & 0.006"
Number of Feeds	3	3
Spindle Drive Motor	3 hp/2 speed	3 hp/2 speed
Elevating Motor	1 hp	1 hp
Coolant Pump Motor	1/8 hp	1/8 hp
<b>Overall Measurements and Weight</b>		
Maximum Machine Height (F)	100"	109-1/2"
Shipping Dim. (LxWxH)	74" x 34" x 87"	80" x 39" x 88"
Net Weight	3,968 lbs	4630 lbs
Shipping Weight	4,300 lbs	4960 lbs

### Dimensions:

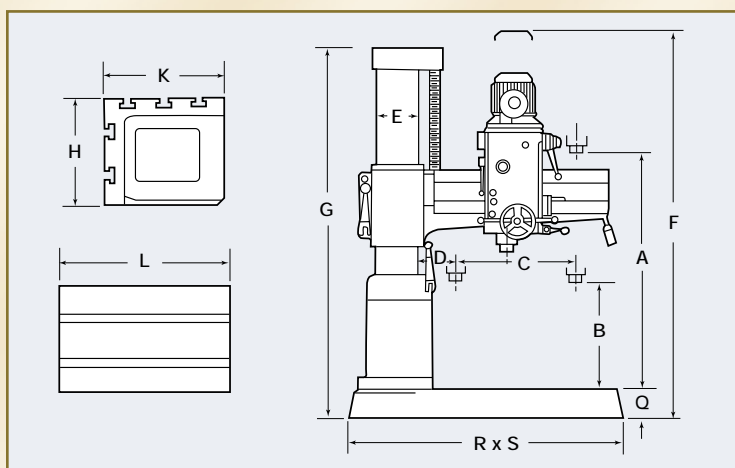

### Capacities:

Model	CL1100	CL1230H
<b>Capacity</b>		
Drilling		
In Steel	1-5/8"	1-5/8"
In Cast Iron	2-3/16"	2-3/16"
Tapping		
In Steel	1"	1"
In Cast Iron	1-1/2"	1-1/2"
Boring		
In Steel	3-3/8"	3-3/8"
In Cast Iron	4-3/4"	4-3/4"