

Series B Geared-drive Round-column Drills

*With Push-button Electromagnetic Clutch
Automatic Feed Control*

The B series is a rugged built Industrial Drilling Machine designed to handle large workpieces and offers the widest range of large capacity drilling and tapping. The B series is equipped with an electromagnetic clutch for precise automatic feed control that can be activated from any of the 4 white push-buttons built into the end of the feed crank handles.

Standard Features and Equipment:

- Drilling capacity in steel: 2.75" (70mm) maximum
- Drilling capacity in cast iron: 3.15" (80mm) maximum
- Tapping capacity in steel: 2" (50mm) maximum
- Tapping capacity in cast iron: 2.36" (60mm) maximum
- Automatic feed reversing system for tapping on "RS" models
- Automatic feed and cut-off by electromagnetic clutch
- Hardened and ground high quality steel gears
- Speed plate and selecting levers on front of head
- Gear box lubrication by automatic pump
- Machine base with 2 T-slots, coolant tank and pump
- Large rotating table with 3 T-slots
- Feed crank wheel for manual feed
- Front hand wheel for fine feed work
- Depth scale and adjustable depth stop
- Automatic tool ejector • Work Light
- Built-in low voltage electrical equipment in machine head
- Emergency STOP • Drill guard with microswitch

Optional Equipment:

- Rotating table and tilting support • 8" column riser
- Automatic pitch control tapping with single speed brake motor
- Automatic pitch control tapping with pneumatic rapid approach
- Master guide spindle and nut set for automatic pitch control tapping
- Pneumatic counterbalance with rapid approach and retract
- Pneumatic counterbalance with rapid approach and retract for tube and and profile drilling
- Pneumatic counterbalance with rapid approach and retract with pitch controlled tapping
- 50% lower feed range • Mechanical spotface device
- Pneumatic counterbalance • Multi-spindle head guide rod
- Union, dragging cone and assembly for multi-spindle head
- START-STOP and emergency STOP pendent control
- Cross slide table • Worklight with magnetic base
- Cycle start foot pedal • Foot pedal for reversing
- Coolant system with independent container



B50



*Built-in low voltage electrics and
automatic tool ejection system lever*

Capacities, Specifications and Dimensions

Standard Models Auto feed reversing for tapping Models	B35 B35RS	B40 B40RS	B45 B45RS	B50 B50RS	B60 B60RS	B70 B70RS
Capacities:						
Maximum drilling capacity in steel	1.38" (35mm)	1.57" (40mm)	1.77" (45mm)	1.97" (50mm)	2.36" (60mm)	2.75" (70mm)
Maximum drilling capacity in cast iron	1.77" (45mm)	2.17" (50mm)	2.17" (55mm)	2.36" (60mm)	2.75" (70mm)	3.15" (80mm)
Maximum tapping capacity in steel	1" (27mm)	1.3" (33mm)	1.3" (33mm)	1.42" (36mm)	1.65" (42mm)	2" (50mm)
Maximum tapping capacity in cast iron	1.3" (33mm)	1.57" (40mm)	1.57" (40mm)	1.65" (42mm)	2" (50mm)	2.36" (60mm)
Specifications:						
Spindle taper	4MT	4MT	4MT	4MT	5MT	5MT
Quill diameter	2.95" (75mm)	3.46" (88mm)	3.46" (88mm)	3.46" (88mm)	3.54" (90mm)	3.54" (90mm)
Spindle travel (drilling depth)	7.87" (200mm)	7.87" (200mm)	7.87" (200mm)	9.06" (230mm)	10.24" (260mm)	10.24" (260mm)
Main motor power	2Hp (1.5Kw)	3Hp (2.2Kw)	3Hp (2.2Kw)	4Hp (3Kw)	5.5Hp (4Kw)	7.5Hp (5.5Kw)
Coolant pump motor power	.1Hp (.07Kw)	.1Hp (.07Kw)	.1Hp (.07Kw)	.1Hp (.07Kw)	.12Hp (.08Kw)	.12Hp (.08Kw)
Number of speeds (see speed charts)	9	9	9	9	12	12
Number of automatic feeds	3	4	4	6	6	6
Auto feed range: in./rev. (mm/rev)	.0039/.0079/.0118 (0.1-0.2-0.3)	.0039/.0079/.0118/.0157 (0.1-0.2-0.3-0.4)		.0039/.0079/.0118/.0157/.0197/.0236 (0.1-0.2-0.3-0.4-0.5-0.6)		
Dimensions and Weights						
Height (A)	81.2" (2285mm)	92.4" (2390mm)	92.4" (2390mm)	97.4" (2475mm)	103.9" (2640mm)	103.9" (2640mm)
Base: length x width (B)	31.5" x 18.5" (800x470mm)	31.9" x 21.3" (810x560mm)	31.9" x 21.3" (810x560mm)	33.9" x 21.7" (860x550mm)	35.8" x 23.2" (910x590mm)	35.8" x 23.2" (910x590mm)
Base to spindle (C)	47.24" (1200mm)	49.61" (1280mm)	49.61" (1280mm)	51.18" (1300mm)	49.21" (1250mm)	49.21" (1250mm)
Spindle center to column (D)	14.57" (370mm)	15.16" (385mm)	15.16" (385mm)	14.57" (370mm)	15.75" (400mm)	15.75" (400mm)
Spindle to Table (E)						
Minimum	4.72" (120mm)	5.51" (140mm)	5.12" (130mm)	5.91" (150mm)	3.15" (80mm)	3.15" (80mm)
Maximum	30.71" (780mm)	30.71" (780mm)	30.31" (770mm)	30.71" (770mm)	25.98" (660mm)	25.98"
Worktable: length x width (F)	18.9" x 22.1" (480x560mm)	18.9" x 22.1" (480x560mm)	20.5" x 24.4" (520x620mm)	20.5" x 24.4" (520x620mm)	23.6" x 27.6" (600x700mm)	23.6" x 27.6" (600x700mm)
Base height (G)	4.72" (120mm)	5.31" (135mm)	5.31" (135mm)	5.71" (145mm)	6.3" (160mm)	6.3" (160mm)
Column diameter (H)	6.3" (160mm)	7.09" (180mm)	7.09" (180mm)	7.87" (200mm)	8.66" (220mm)	8.66" (220mm)
Net weight	1,080 lbs (490Kg)	1,345 lbs (610Kg)	1,411 lbs (640Kg)	1,587 lbs (720Kg)	1,808 lbs (820Kg)	1,852 lbs (840Kg)
Shipping weight	1,257 lbs (570Kg)	1,532 lbs (695Kg)	1,598 lbs (725Kg)	1,725 lbs (805Kg)	2,025 lbs (920Kg)	2,072 lbs (940Kg)
Shipping dimension (length x width x height)	28" x 40" x 95" (.7 x .1 x 2.4m)	28" x 40" x 103" (.7 x .1.2 x 2.6m)	28" x 40" x 103" (.7 x .1.2 x 2.6m)	28" x 40" x 103" (.7 x .1.2 x 2.6m)	32" x 52" x 111" (.8 x .1.3 x 2.8m)	32" x 52" x 111" (.8 x .1.3 x 2.8m)

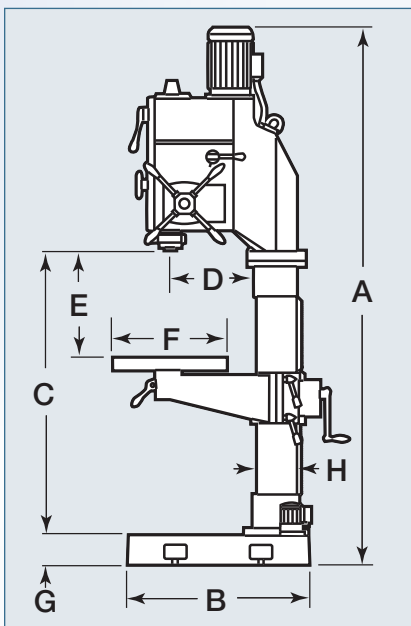

Standard motor: 1800 rpm

Model	Spindle speeds (rpm)
B35	95-135-190-267-380-534-750-1065-1500
B40/45	73-103-149-232-325-472-695-976-1415
B50	66-91-133-206-288-418-617-866-1255
B60	76-96-127-165-238-296-392-513-670-838-1107-1446
B70	62-81-104-133-191-250-321-410-532-683-878-1120

Standard Fixed Table Models

Model	Description (Dimension see page 21)
1B35	29.1" (740mm) with Fixed Table
1B35RS	29.1" (740mm) with Fixed Table and Tapping
1B40	29.5" (750mm) with Fixed Table
1B40RS	29.5" (750mm) with Fixed Table and Tapping
1B45	29.5" (750mm) with Fixed Table
1B45RS	29.5" (750mm) with Fixed Table and Tapping
1B50	29.1" (740mm) with Fixed Table
1B50RS	29.1" (740mm) with Fixed Table and Tapping

"RS" models are equipped with automatic feed reversing system for tapping.

Optional spindle motors

Model	Motor	Speed range
B35	1200 rpm	63-1000 rpm
B35	3600 rpm	190-3000 rpm
B35	900/1800 rpm	47-1500 rpm
B35	1800-3600 rpm	95-3000 rpm
B40/45	1200 rpm	50-948 rpm
B40/45	3600 rpm	146-2830 rpm
B40/45	900/1800 rpm	36-1415 rpm
B40/45	1800-3600 rpm	73-2830 rpm
B50	1200 rpm	46-878 rpm
B50	3600 rpm	132-2510 rpm
B50	900/1800 rpm	33-1255 rpm
B50	1800-3600 rpm	66-2510 rpm
B60	1200 rpm	54-1012 rpm
B60	3600 rpm	152-2892 rpm
B60	900/1800 rpm	38-1446 rpm
B60	1800-3600 rpm	76-2892 rpm
B70	1200 rpm	40-748 rpm
B70	3600 rpm	124-2440 rpm
B70	900/1800 rpm	31-1120 rpm
B70	1800/3600 rpm	62-2240 rpm