

# Series C Belt/Geared-drive Round-column Drills

*With Push-button Electromagnetic Clutch  
Automatic Feed Control*

The C-series of Industrial Drilling Machines are capable of handling heavier workpieces with a wide range of drilling and tapping capacities. Designed for easy operation with a electromagnetic clutch for precise automatic feed control that can be activated from the feed crank handle or by the lever on the front of machine head.

## Standard Features and Equipment:

- Drilling capacity in steel: 1.97" (50mm) maximum
- Drilling capacity in cast iron: 2.36" (60mm) maximum
- Tapping capacity in steel: 1.68" (42mm) maximum
- Tapping capacity in cast iron: 2" (50mm) maximum
- Automatic feed reversing system for tapping
- Automatic feed and cut-off by electromagnetic clutch
- Hardened and ground high quality steel gears
- Speed plate and selecting levers on front of head
- Gear box lubrication by automatic pump
- Machine base with 2 T-slots, coolant tank and pump
- Large rotating table with 3 T-slots
- Feed crank wheel for manual feed
- Front hand wheel for fine feed work
- Depth scale and adjustable depth stop
- Automatic tool ejector • Work Light
- Built-in low voltage electrical equipment in machine head
- Emergency STOP • Drill guard with microswitch

## Optional Equipment:

- Rotating table and tilting support • 8" column riser
- Automatic pitch control tapping with single speed brake motor
- Automatic pitch control tapping with pneumatic rapid approach
- Master guide spindle and nut set for automatic pitch control tapping
- Pneumatic counterbalance with rapid approach and retract
- Pneumatic counterbalance with rapid approach and retract for tube and and profile drilling
- Pneumatic counterbalance with rapid approach and retract with pitch controlled tapping
- 50% lower feed range • Mechanical spotface device
- Pneumatic counterbalance • Multi-spindle head guide rod
- Union, dragging cone and assembly for multi-spindle head
- START-STOP and emergency STOP pendent control
- Cross slide table • Worklight with magnetic base
- Cycle start foot pedal • Foot pedal for reversing
- Coolant system with independent container



# Capacities, Specifications and Dimensions

Standard Models	BC40V	BC40VE	BC50V	BC50VE
<b>Capacities:</b>				
Maximum drilling capacity in steel	1.57" (40mm)	1.57" (40mm)	1.97" (50mm)	1.97" (50mm)
Maximum drilling capacity in cast iron	1.97" (50mm)	1.97" (50mm)	2.36" (60mm)	2.36" (60mm)
Maximum tapping capacity in steel	1.42" (36mm)	1.42" (36mm)	1.65" (36mm)	1.65" (36mm)
Maximum tapping capacity in cast iron	1.65" (36mm)	1.65" (36mm)	1.97" (50mm)	1.97" (50mm)
<b>Specifications:</b>				
Spindle taper	4MT	4MT	4MT	4MT
Quill diameter	3.46" (87.9mm)	3.46" (87.9mm)	3.46" (87.9mm)	3.46" (87.9mm)
Spindle travel (drilling depth)	7.87" (200mm)	7.87" (200mm)	7.87" (200mm)	7.87" (200mm)
Main motor power	4 Hp (3 Kw)	4 Hp (3 Kw)	5.5 Hp (4 Kw)	5.5 Hp (4 Kw)
Coolant pump motor power	.1Hp (.07 Kw)	.1Hp (.07 Kw)	.1Hp (.07 Kw)	.1Hp (.07 Kw)
No. of variable speeds ranges and type	3 mechanical	3 electronic	3 mechanical	3 electronic
Low range (rpm)	72-240	30-230	72-240	30-230
Med range (rpm)	240-720	90-730	240-720	90-730
High range (rpm)	720-2200	190-1500	720-2200	190-1500
Number of automatic feeds	4	4	4	4
Auto feed range	.0039/.0079/.118/.157 (in./rev.) (0.1/0.2/0.3/0.4 mm/rev)			
<b>Floor Drill Dimensions and Weights</b>				
Height (A)	81.9" (2080mm)	81.9" (2080mm)	83.5" (2120mm)	83.5" (2120mm)
Base: length x width (B)	31.9" x 26.3" (810x540mm)	31.9" x 26.3" (810x540mm)	33.9" x 21.7" (860x550mm)	33.9" x 21.7" (860x550mm)
Base to spindle (C)	46.1" (1170mm)	46.1" (1170mm)	49" (1246mm)	49" (1246mm)
Spindle center to column (D)	15.15" (385mm)	15.15" (385mm)	14.56" (370mm)	14.56" (370mm)
Spindle to Table (E)				
Minimum	1.97" (50mm)	1.97" (50mm)	1.57" (40mm)	1.57" (40mm)
Maximum	27.16" (690mm)	27.16" (690mm)	26" (660mm)	26" (660mm)
Worktable: length x width (F)	18.9" x 22" (480x560mm)	18.9" x 22" (480x560mm)	20.5" x 24.4" (520x620mm)	20.5" x 24.4" (520x620mm)
Base height (G)	5.31" (135mm)	5.31" (135mm)	5.71" (145mm)	5.71" (145mm)
Column diameter (H)	7.09" (180mm)	7.09" (180mm)	7.87" (200mm)	7.87" (200mm)
Net weight	1,455 lbs (660kg)	1,455 lbs (660kg)	1,675 lbs (760kg)	1,675 lbs (760kg)
Shipping weight	1,653 lbs (750kg)	1,653 lbs (750kg)	1,874 lbs (850kg)	1,874 lbs (850kg)
Shipping dimension (length x width x height)	32" x 51" x 91" (.8 x 1.3 x 2.3m)		36" x 55" x 91" (.9 x 1.4 x 2.3m)	

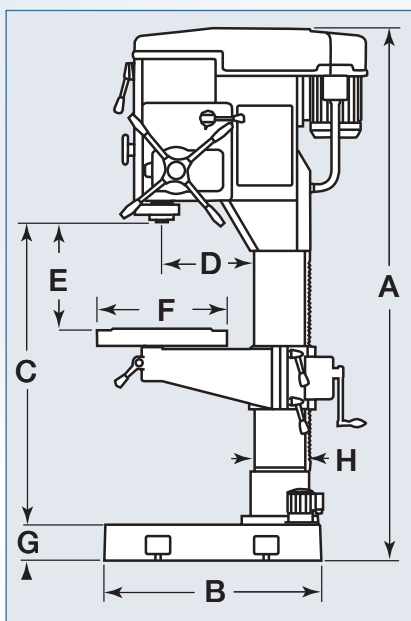

## Standard motor: 1800 rpm

Model	Spindle speeds (rpm)
BC40V	Mechanical Variable Speed: 72-1800 rpm
BC50V	Mechanical Variable Speed: 36-1800 rpm
BC40VE	Electronic Variable Speed: 72-1800 rpm
BC50VE	Electronic Variable Speed: 36-1800 rpm

## Optional spindle motors

Motor	Speed range
-------	-------------

## Standard Fixed Table Models

Model	Description
1BC40V	30.3" (770mm) drill with Fixed Table
1BC50V	29" (736mm) drill with Fixed Table
1BC40VE	30.3" (770mm) drill with Fixed Table
1BC50VE	29" (736mm) drill with Fixed Table