



Clausing 12" (305mm) Wet Cutting Semi-Automatic Miter Bandsaw

Features:

- 0°-45° Miter cutting, make angle cuts without swinging material to be cut
- 2 Hp (1.5kw) main drive with magnetic starter and overload protection
- Variable speed drive
- 230/460 60 cycle 3 phase electricals
- Recirculating coolant system with application through both guides
- Solid carbide blade guides with rollers
- Quick position vise
- Automatic shut-off at end of cut
- Totally enclosed transmission
- Blade cleaning brush
- Cast iron bed
- 1" (254mm) wide blade
- Stock stop
- Easily adjusted head feed with power lift
- Two (2) year limited warranty

Specifications

Model	MS1218VS
Drive Motor	2 Hp, (1.5kw) 230/460v 3 phase
Hydraulic Motor	0.25 Hp (.19kw)
Coolant Pump	0.125 Hp (.1kw)
Band Wheel Dia.	15.4" (391mm)
Blade	1" x .035" x 11'-4.5" (25 x .9 x 3467mm)
Bed Height	21.75" (552mm)
Vise Opening	18" (457mm)
Blade Speeds	80-360 fpm (24-110 mfm) variable speed
90° Cutting Capacity	
Round	12" (305mm)
Square	10" x 10" (254 x 254mm)
Rectangular	10" x 16" (254 x 406mm)
45° Cutting Capacity	
Round	8" (203mm)
Square	8" x 8" (203 x 203mm)
Rectangular	8" x 12" (203 x 305mm)
Width	75" (1905mm)
Depth (with stock stop)	34" (49.5") (864(1257)mm)
Height (head-up)	64" (1626mm)
Height (head-down)	41" (1041mm)
Net Weight	880 lbs (400kg)
Shipping Weight	1,100 lbs (500kg)

Accessories

- P10 Stock Stand Assembly 21" - 30"
- RT0516 Roller Table Assembly 5' x 16"
- RT1016 Roller Table Assembly 10' x 16"
- BT01 Bandsaw Blade Tension Gauge

Cutting Capacities:

Capacity at 90°

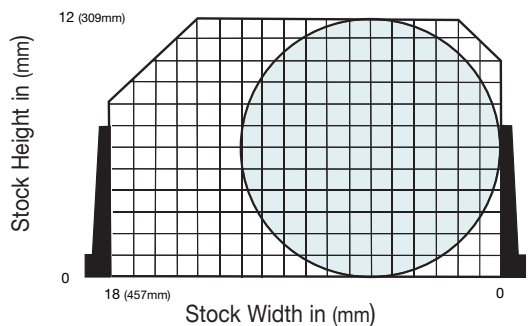

Capacity at 45°

